

NOTES: SEE SHEET LA-2 FOR EXISTING TREE & PALM SPECS, & CALCULATIONS. SEE SHEET LA-3 FOR PROPOSED TREE & PALM REPLACEMENT SPECIES & LOCATIONS.

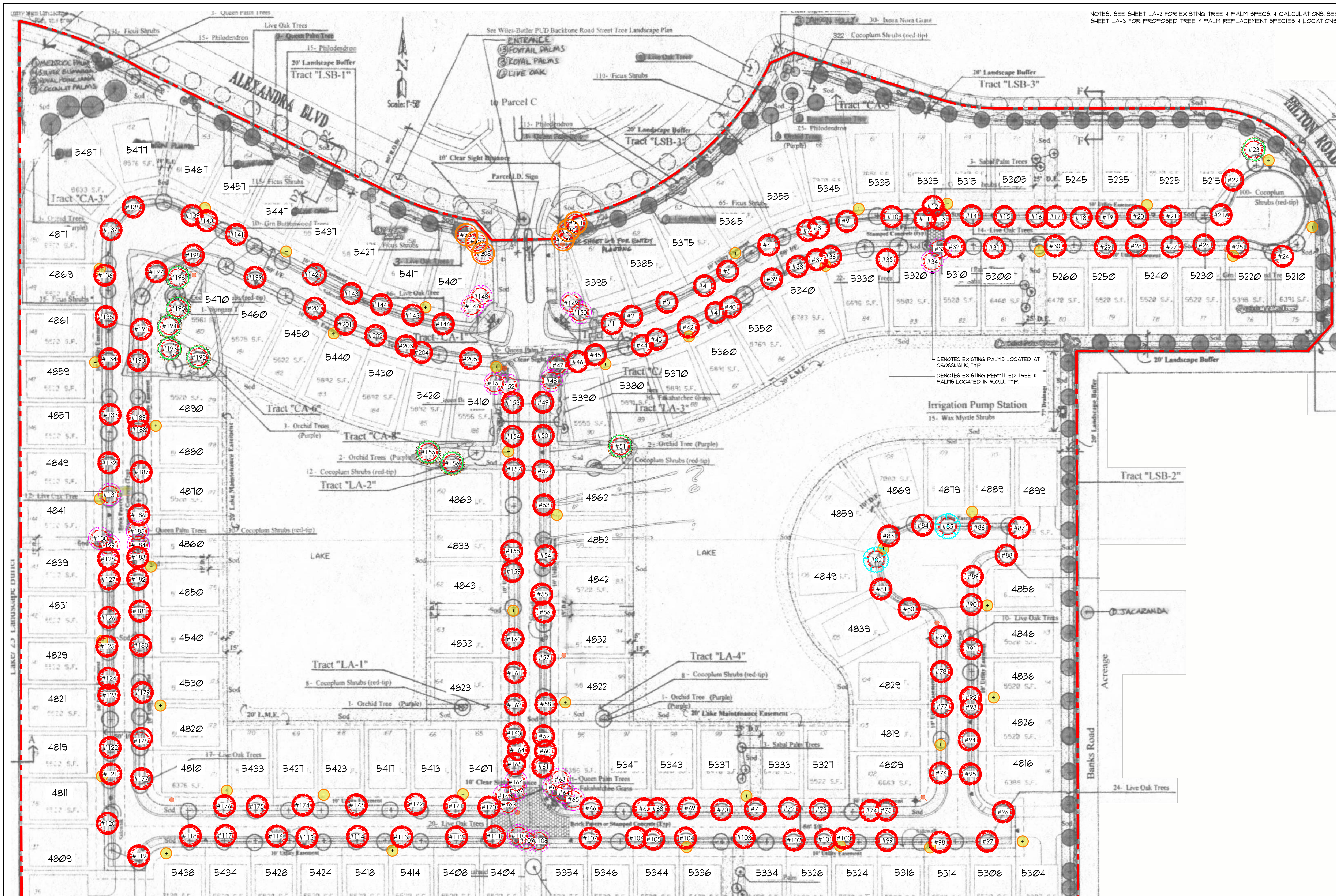

DENOTES EXISTING PALMS LOCATED AT CROSSWALK, TYP.
DENOTES EXISTING PERMITTED TREE & PALMS LOCATED IN R.O.W, TYP.

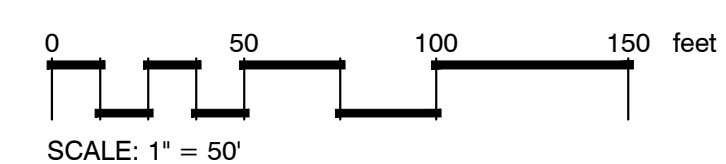

 EXISTING TREE & PALM DISPOSITION PLAN

DAVIDFONTDESIGN
INTERIOR | EXTERIOR
11820 N.W. 37TH ST. SUITE 1
CORAL SPRING, FLORIDA 33065
PH: 954.283.8839 FAX: 954.773.9841
EMAIL: INFO@DAVIDFONTDESIGN.COM

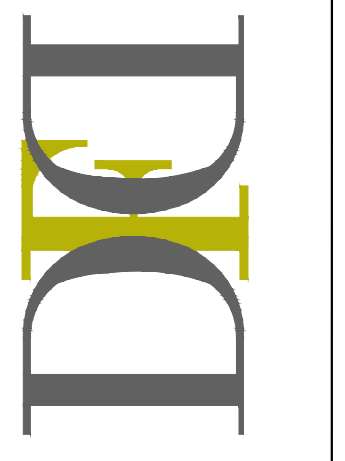

INDIGO LAKES | LAKE ST. CROIX
COCONUT CREEK, FLORIDA 33073

DAVID FONT, A.S.A. P.L.A.
LA 6666822

REVISIONS:

SUBMITTAL DATE
1/25/2021

LA-1A

NOTES: SEE SHEET LA-2 FOR EXISTING TREE & PALM SPECIES & CALCULATIONS. SEE SHEET LA-3 FOR PROPOSED TREE & PALM REPLACEMENT SPECIES & LOCATIONS.

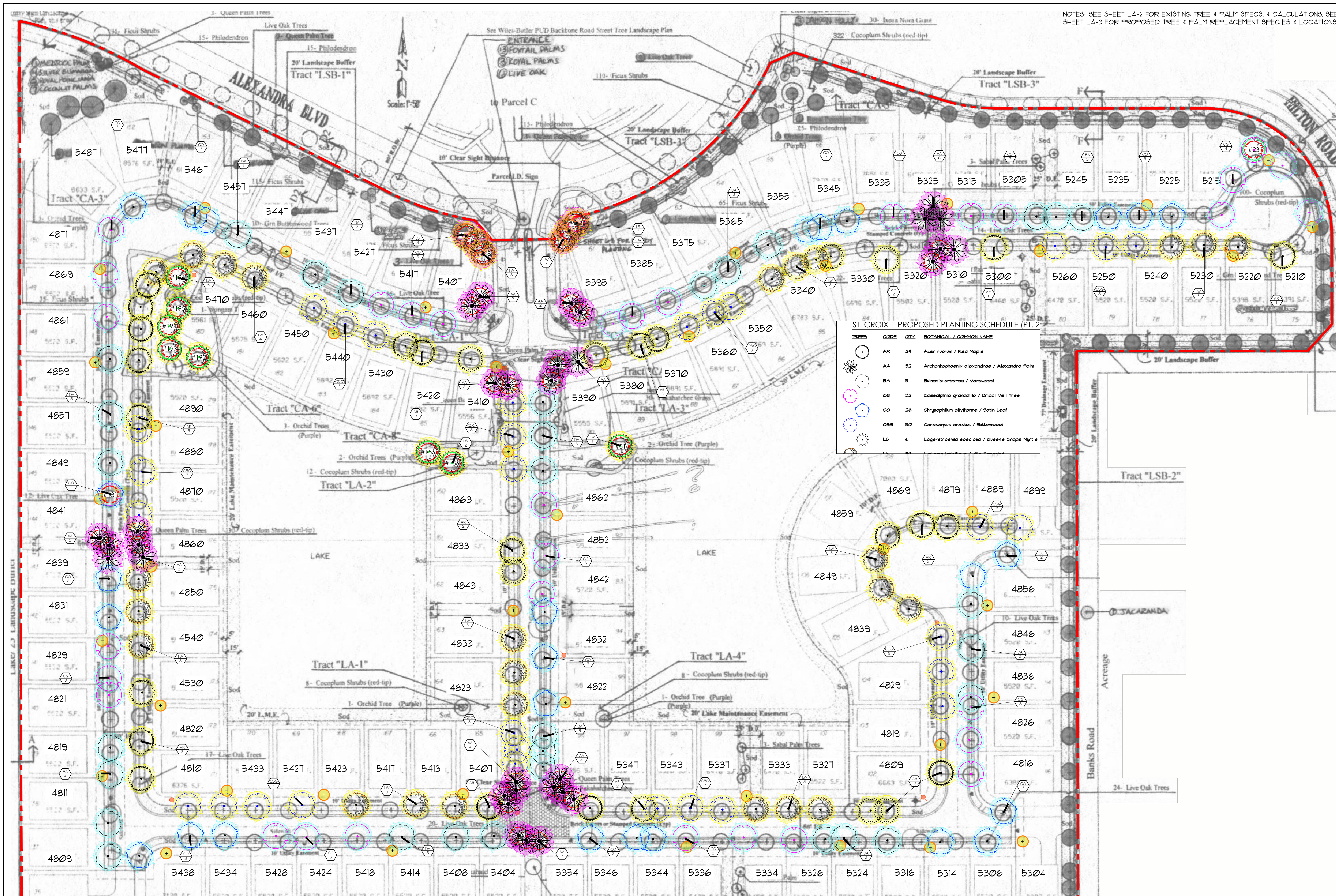

ST. CROIX | PROPOSED PLANTING SCHEDULE (PT. 2)

TREES	CODE	QTY	BOTANICAL / COMMON NAME
●	AR	24	Acer rubrum / Red Maple
✿	AA	52	Archontophoenix alexandrae / Alexandra Palm
●	BA	51	Bulnesia arborea / Verawood
●	GB	52	Gaespalmia granadilla / Bridal Veil Tree
●	GO	26	Chrysothamnus oliviforme / Satin Leaf
●	CSB	50	Conocarpus erectus / Buttonwood
●	LS	6	Lagerstroemia speciosa / Queen's Grape Myrtle

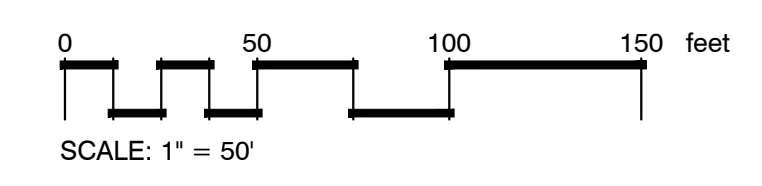

PROPOSED LANDSCAPE PLAN & SCHEDULE

DAVIDFONTDESIGN
 INTERIOR EXTERIOR
 11820 N.W. 37TH ST. SUITE 1
 CORAL SPRING, FLORIDA 33065
 PH: 954.283.8839 FAX: 954.773.9811
 EMAIL: INFO@DAVIDFONTDESIGN.COM

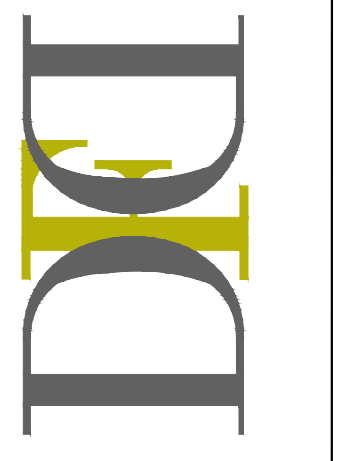

INDIGO LAKES | LAKE ST. CROIX
 COCONUT CREEK, FLORIDA 33073

DAVID FONT, A.S.A. P.L.A.
 LA 6666822

REVISIONS:

SUBMITTAL DATE
 1/25/2021

LA-3A

ST. CROIX | PROPOSED PLANTING SCHEDULE

TREES	CODE	QTY	BOTANICAL / COMMON NAME	CONT.
	AR	24	Acer rubrum / Red Maple	12 min. height, 5' spread, 2.0 inch min. caliper, Grade FL #1 or better
	AA	32	Archontophoenix alexandriae / Alexandra Palm	Min. Req. 8' C.T.
	BA	31	Bulnesia arborea / Verawood	10' min height, 4' spread, 2" min. caliper
	CG	32	Caesalpinia granadillo / Bridal Veil Tree	10' min height, 4' spread, 2" min. caliper
	CO	26	Chrysophyllum oliviforme / Satin Leaf	10' min height, 4' spread, 2" min. caliper
	CSS	30	Conocarpus erectus / Buttonwood	12 min. height, 5' spread, 2.0 inch min. caliper, Grade FL #1 or better
	LS	6	Lagerstroemia speciosa / Queen's Grape Myrtle	12' min. O.A., 2' min. Cal. STD
	LK	25	Lyallia latistylava / Wild Tamarind	12 min. height, 5' spread, 2.0 inch min. caliper, Grade FL #1 or better

REPLACEMENT CATEGORY #1 TREE SPECIES INCLUDE:



REPLACEMENT CATEGORY #2 TREE SPECIES INCLUDE:



TREE DEMOLITION NOTES:

THE CONTRACTOR SHALL CALL FOR AND ATTEND AN INSPECTION OF EXISTING CONDITIONS BY THE OWNER PRIOR TO COMMENCING WORK. THE CONTRACTOR WILL PREPARE A REPORT OF EXISTING CONDITIONS AS A MATTER OF RECORD, TO INCLUDE PHOTOGRAPHS. THE CONTRACTOR WILL ACCEPT THE EXISTING CONDITIONS AS A REFERENCE POINT FOR CONDITION OF THE SITE. EXISTING CONDITIONS WILL THEN BECOME THE RESPONSIBILITY TO KEEP INTACT.

NOTE #1: PLEASE REFER TO THE FOLLOWING DETAIL FOR ALL TREES AND PALMS, WHICH ARE LOCATED ADJACENT TO PRIVATE DRIVEWAYS.

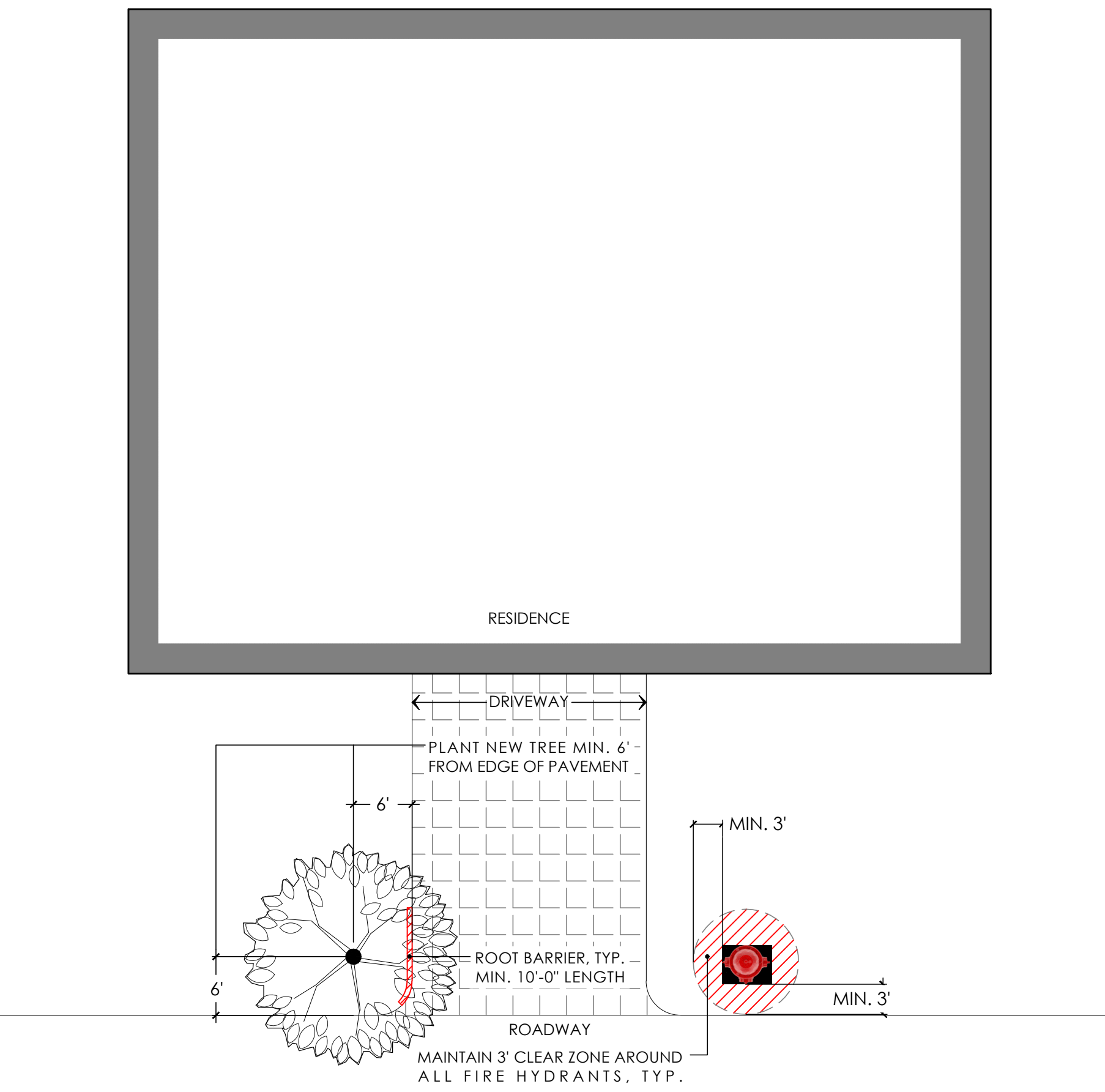

NOTE #2: IF PLANTING THE NEW TREE 6' AWAY FROM EDGE OF DRIVEWAY AND ROAD IS NOT POSSIBLE DUE TO UTILITIES, TREES OR OTHER UNFORESEEN OBSTACLE, THEN PLACE THE TREE AS FAR AS POSSIBLE FROM BOTH DRIVEWAY AND ROADWAY TO MINIMIZE ROOT IMPACT ON HARDSCAPE

PROPOSED TREE & PALM PLACEMENT DETAIL

NTS

CITY OF COCONUT CREEK
STANDARD LANDSCAPE NOTES



NOTE:
ALL PLANT MATERIAL
TO BE FLORIDA #1 OR BETTER

- All landscape and specifications shall meet or exceed the minimum requirements as provided in the City of Coconut Creek Land Development Code. Plans are incomplete without written notes and specifications.
- All planting material shall meet or exceed Florida Grade #1 as specified in Grades and Standards for Nursery Plants, current edition. Trees shall not be tipped, topped, or shaped prior to installation.
- Landscape shall be placed to edge of abutting streets, canals, lakes or other lands.
- All mechanical equipment, air conditioning, irrigation pump stations and equipment, FPL transformers, pool pumps, etc., must be screened on three (3) sides by landscape shrubs.
NOTE: The quantity of screening shrubs is in addition to the required number of shrubs as provided in the code calculation table. All screening shrubs shall be planted for proper operation of equipment being screened and/or per the requirements of the utility as necessary. All hedge material required for screening purposes shall be planted with branches touching. Adjust on-center spacing as necessary and/or provide additional plants to provide an adequate screen.
- Sight distance concerns must be maintained for clear sight visibility from thirty (30) inches to seventy-two inches, tree trunks excluded. Measurement shall be made from top of root ball planted at proper elevation.
- Guying/staking practices shall not permit nails, screws, wires, etc., to penetrate outer surfaces of trees, palms or other plant material. Trees, palms and plant material rejected due to this practice shall be replaced with the inspector on site.
- Burlap material, wire cages, plastic/canvas straps, etc., must be cut and removed from the top one-half (1/2) depth of the root ball. Trees and shrubs grown in grow bags or grow bag type material must have such material REMOVED ENTIRELY prior to planting the tree or shrub.
- All plant material shall be free of pests, insects, disease, weeds, etc.
- All required landscape material shall be installed using a planting soil mix comprised of a type appropriate to the individual proposed plant material and the native soil found on the site.
- All plant material shall be planted at the proper depth, as originally grown and/or so the top of the root ball is flush or slightly above finished grade immediately after planting. All trees should provide trunk taper when properly planted at the correct planting depth.
- All plant material shall be watered in at time of planting to eliminate air pockets in the root zone area.
- Upon completion of work, the site shall be cleared of all debris, superfluous materials, and equipment caused by this permit to the satisfaction of the inspector.
- Refer to Coconut Creek Fire Equipment Clear Zone diagram to maintain a safe zone fronting fire hydrants.
- Do not plant trees, shrubs or groundcover within Electric Meter Clear Zone. Provide a safe zone as described by the Electrical Inspector.
- All landscaped areas shall be provided with an underground fully automatic irrigation system using pop-up sprinklers. System shall provide 100% coverage with 50% overlap (minimum) using rust free water, except preserved areas remaining in natural state. A rain sensor device or switch shall be installed that will override the irrigation system when adequate rainfall has occurred. Water shall not be directed and/or provided onto impervious surfaces and/or be designed or installed to throw water over an impervious surface such as a sidewalk, etc. Hours of operation for all irrigation systems shall be limited to 5:00 p.m. to 8:00 a.m. only or as may be further restricted by South Florida Water Management District or other jurisdictional agency.
- Irrigation permits and plans shall be submitted for approval at time of building permits.
- All non-single family or duplex irrigation systems other than City water systems shall require a South Florida Water Management District water use permit prior to issuance of an irrigation permit and installation of the irrigation system as required.
- All site amenities to include site street lights, landscape common open space, irrigation common open space, buffers, berms, landscape entry features, etc. leading up to and including the model center and/or first certificate of occupancy must be completed and functional prior to issuance of the first requested certificate of occupancy.
- The height of all required, designed and installed berms shall be from the highest adjacent point whether it is the sidewalk, parking area, vehicular use area, surrounding ground, etc. Where a berm abuts a sidewalk, there shall be a one (1) foot level sod area adjacent to the sidewalk prior to the start of incline for the berm.
- An inspection is required prior to the backfilling of trees/palms in all parking medians and islands.

NOTE: THIS COMMENT SHEET IS TO BE PLACED ON ALL LANDSCAPE PLANS "AS IS".

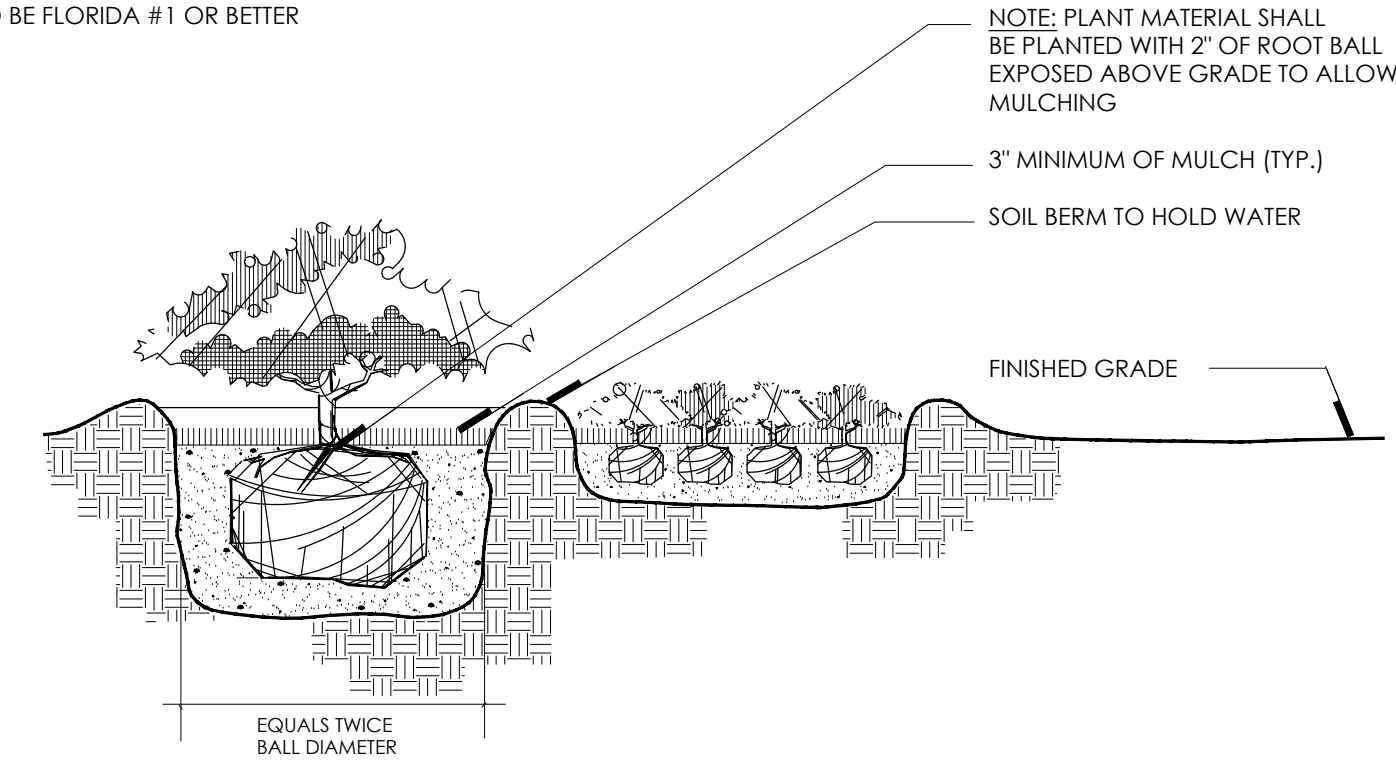

A SHRUB AND GROUND COVER DETAIL
SECTION NOT TO SCALE

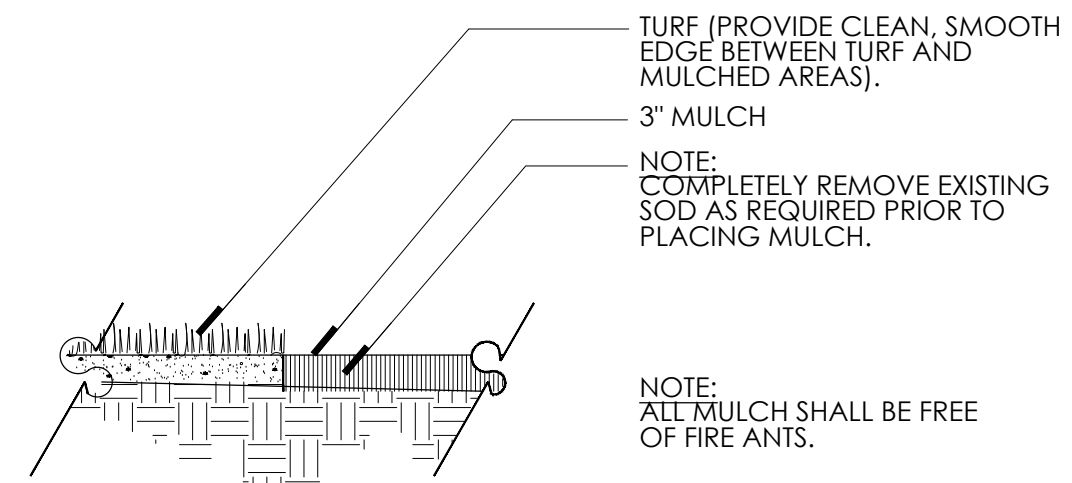

B TURF/MULCH DETAIL
SECTION NOT TO SCALE

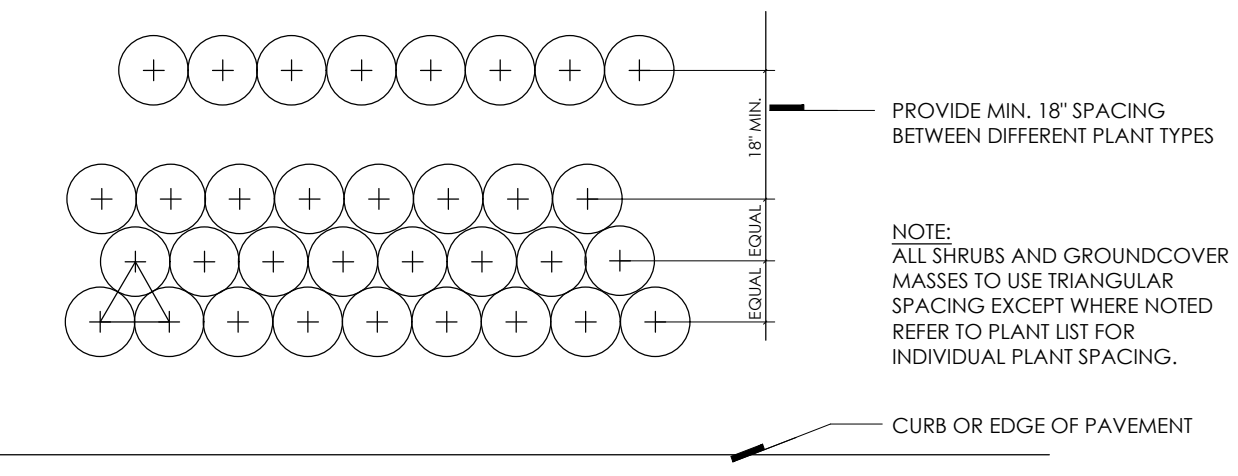

C SHRUB/GROUND COVER SPACING DETAIL
PLAN NOT TO SCALE

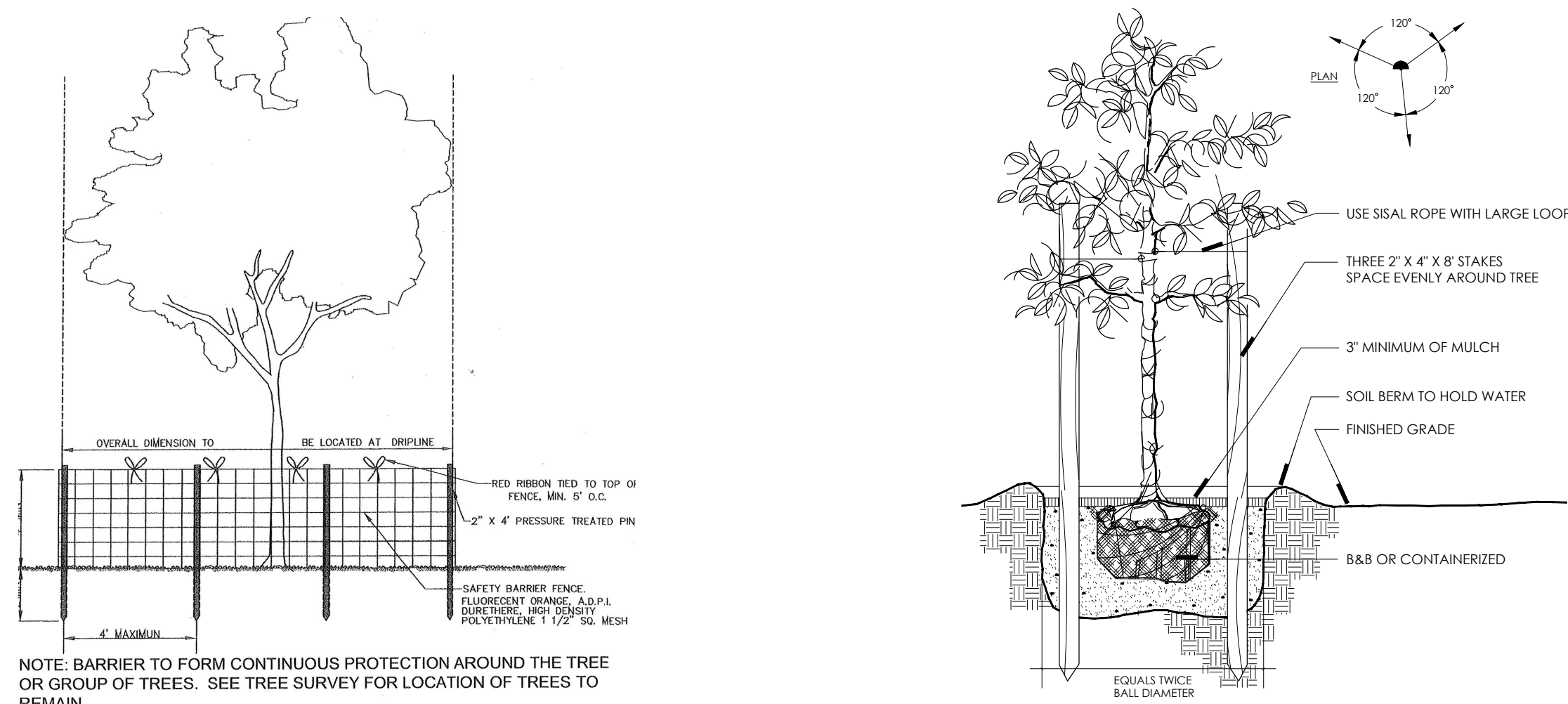

F TREE PROTECTION BARRICADE DETAIL
SECTION NOT TO SCALE

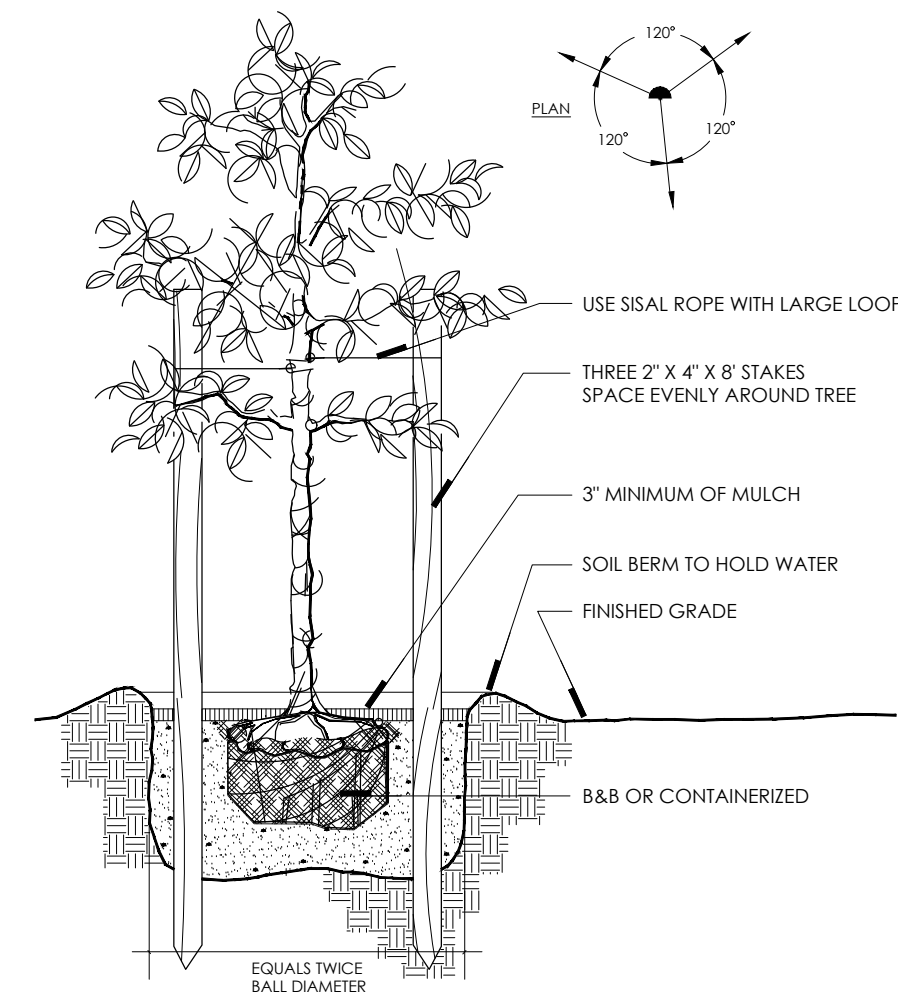

E TREE DETAIL
SECTION NOT TO SCALE

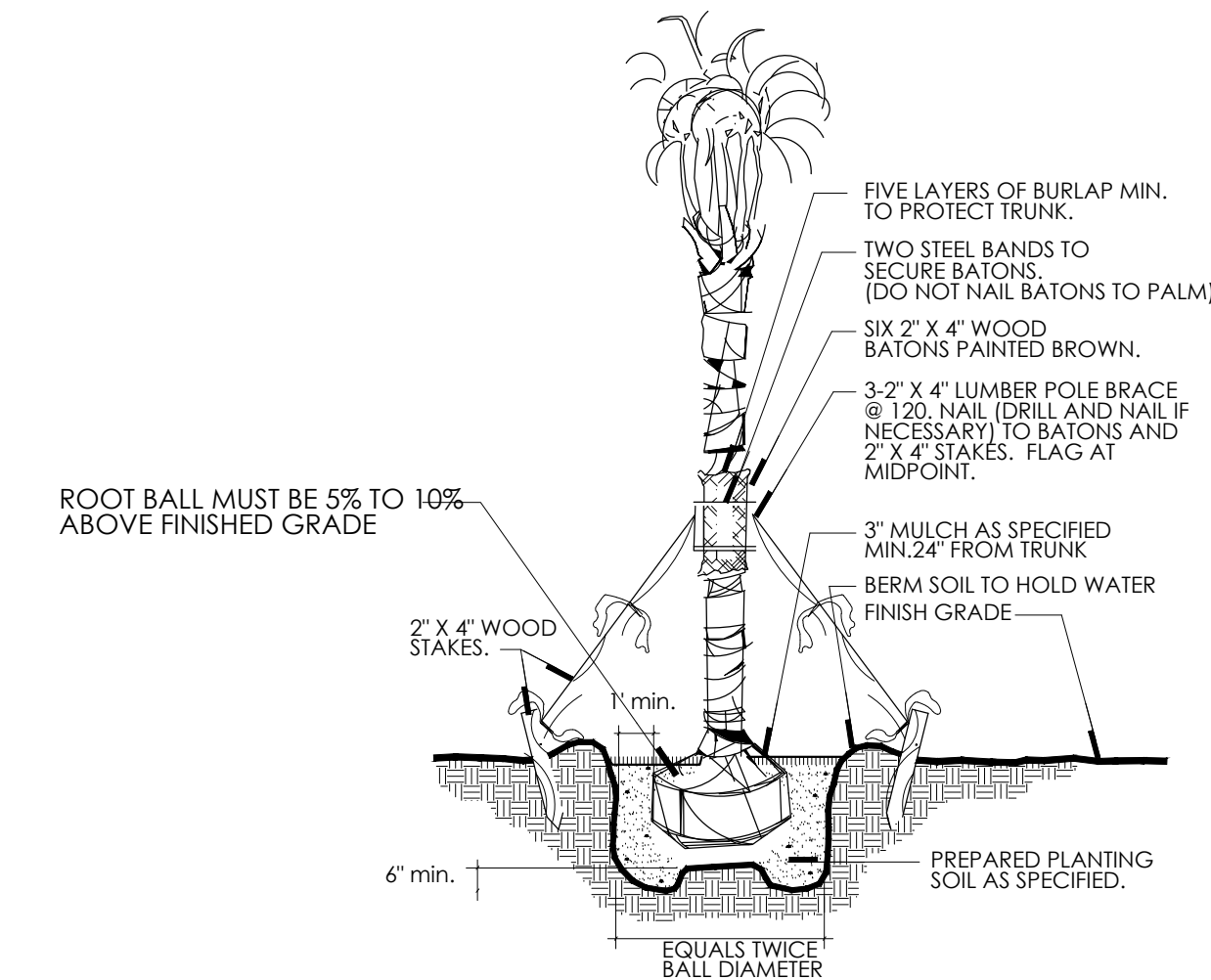

F PALM DETAIL
SECTION NOT TO SCALE

DAVID FONT DESIGN
INTERIOR EXTERIOR
11820 N.W. 37TH ST. #501
CORAL SPRING, FLORIDA 33065
PH: 954.283.8839 FAX: 954.773.9841
EMAIL: INFO@DAVIDFONTDESIGN.COM

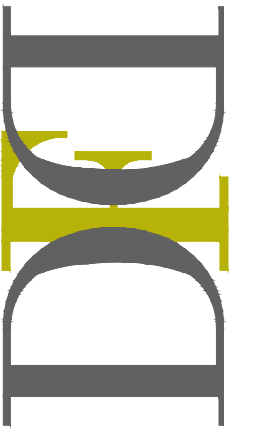

INDIGO LAKES | LAKE ST. CROIX
COCONUT CREEK, FLORIDA 33073

DAVID FONT, A.S.A. P.L.A.
LA 6666B22

REVISIONS:

SUBMITTAL DATE

1/25/2021

LA-4A